

Lubricate all seals with clean hydraulic fluid prior to assembly.
Do Not Use Silicone Based Lubricants.

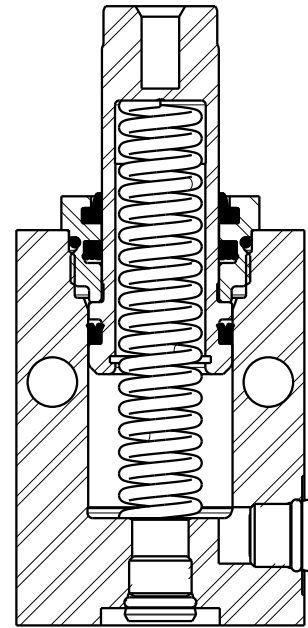
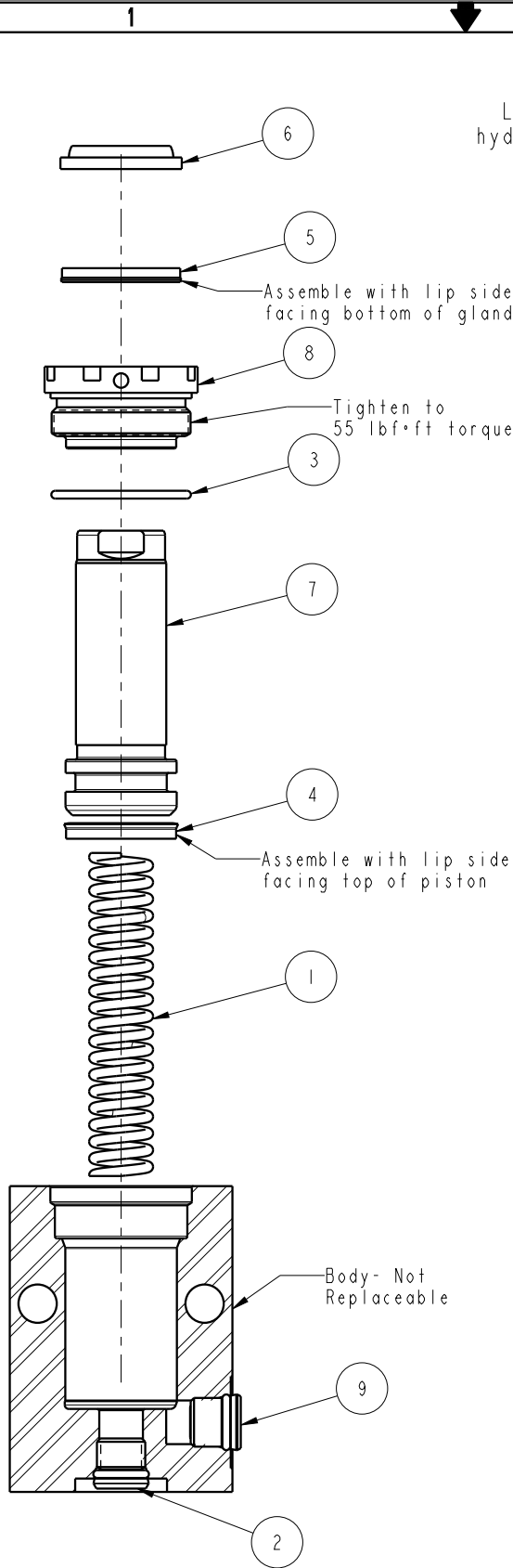

Standard Seal Kit 60-2011-10	Fluorocarbon Seal Kit 6V-2011-10	Spring Kit 61-2011-10
39-0100-14	39-0120-01	23-3130-17
39-0110-45	39-0120-05	
39-0010-11	39-0120-13	
39-0120-08	39-0120-08	

No.	QTY	PART No.	DESCRIPTION
9	1	92090001	ASSY, BREATHER, SAE #4
8	1	82031002	GLAND, CYL, 3900 & 17.8 KN
7	1	82011005	PISTON, CYL, 3900, 1 STRK
6	1	39012008	WIPER, SNAP-IN, (13/16)
5	1	39011045	SEAL, LL, (13/16 X 1/8 X 1/8 X 1-1/8)
4	1	39010014	SEAL, BEVEL, 13/16 x 3/32 x 1
3	1	39001011	O-RING, (-024)
2	1	30601144	PLUG, SOCH, SAE 4
1	1	23313017	SPRING, COMPRESSION

PARTS LIST



VEKTEK, INC.
1334 E. SIXTH AVE. P.O. BOX 625
EMPORIA, KS. 66801 U.S.A.

Model Number
25-1110-11
25-1110-11F

ASSY, CYL, PULL, BB, 1300, 1 STRK

PARTS LIST

SIZE
A

PL2129

REV
G

G	5499	RELEASE	NPETERS	9/23/24
REV	IN ACCORDANCE WITH ECN	EFFECTIVE DATE	REVISED BY	DATE
DRW BY:	BUSH	DRAWING STATUS: Released		
DATE:	12-10-96	PRODUCTION APPROVED FOR RELEASED STATUS ONLY		

FORM FEG035_PL_ASIZE, REV. B

SHEET 1 OF 1